

USER MANUAL INDUSTRIAL DOOR

LH/F



1. Guarantee conditions

The manual has been prepared to be used by qualified workers and cannot be used by people who are not entitled. Should any questions or doubts occur, you are requested to contact PRODUCER company.

The manual presents correct way of montage of garage door hardware only. In order to assembly a garage door with sandwich panel and other devices, the producer should follow manuals of the sandwich panel and other devices. The sandwich panel and other devices should be produced according to European Union rules.

2. Assembly conditions

Unprofessional assembly, any variations of the assembly that are not in accordance with this manual, will be made on the garage door Producer's responsibility.

This also applies to any damages caused by improper use and not following the rules of this manual as well as improper service.

The system presented in this manual should be used in residential buildings only and can be assembled and run by qualified workers only.

1. Make sure that during working with electric devices the power is off.
2. Security devices should never be switched off!
3. Be careful in case of keen edges, use gloves.
4. If visible damages of sectional door occur, stop further using of the door.
5. While assembly/maintenance of the door it is recommended to always use gloves and protection shoes, and during drilling use the protection glasses.
6. Mark out the place of working with a tape so that the children and other people keep a distance.
7. It is recommended that maintenance to be carried out by a professional (company or person).
8. Provide proper lightning.
9. Use the suitable tools, especially for springs torsion.

3. Range of use

Garage door hardware has been designed for use in residential buildings only.

- Max. garage door width: ... mm
- Max. garage door height: ... mm
- Max. garage door weight: ... kg

4. Material used to assembly garage door in the building

Fastening materials for assembly of garage door in the building aren't included in door elements set. Assembling person is obligated to use the suitable connecting materials, that connect the door

construction with lintel.

5. Assembly set

1. Track set (vertical and horizontal)
2. Spring breakdevice
3. Assembling elements of panel, according to used option (hinges, brackets etc.)
4. Steel cables
5. Tubularshaft
6. Springs with fittings
7. Perforated angle or underslung brackets system
8. Box with screws, bolts and other fastening elements.

6. Assembly tools

Tools necessary for proper and quick installation:

1. driller with drill of 8.0mm
2. flatwrench 10 mm,
3. flatwrench 13 mm,
4. pass-key,
5. clamp,
6. suspension line,
7. level,
8. assemblydrawings.

7. Control and service just after assembly

When assembly is finished worker should control if all elements are connected in accordance with the manual:

- lubrication of bearing brackets and rollers,
- lubrication of hinges,
- lubrication of steelcable,
- placement of Identification Card and required warning labels.

8. Passing the finished product to customer

Producer of door passes it to a user and shows him the way of working of the product, teaches him how to use the door and provide the following documents:

- manual of use and service,
- instructions what to do in case of incorrect working of door.

9. Garage door maintenance and overview

Door overview shall be signed in Door Service Book. After 3 months since door assembly, assembling person (service person) makes:

- visual control of all elements,
- control of proper door operating and tighten the fasteners if needed.

After 6 months or after 700 cycles the user shall:

- remove impurities from door that have influence on correct working of door,
- lubricate the bearings and rollers,
- lubricate the hinges.

After 12 months since assembly repairer (assembling person) shall control and maintenance of proper door operating:

- roller (damages, materialconsumption, lubrication),
- control of steel cables consumption, especially connections with cable drums and bottom brackets and working places of cable pulleys if applied,
- control of cable pulleys consumption, if applied,
- spring breakdevicecontrol,
- control of vertical track connection with ceiling,
- control of shaft brackets and spring breaking devices,
- control of seals consumption, and damages
- control of shaft coupler, if applied.

10. Garagedoor operator

All electric devices (including operators) that are a part of garage door shall fulfill requirements of European Union standards. Assembly of operator shall be made in accordance with producer manual. In case of lack of power supply or if there is no separate entrance into the garage, door shall be equipped with drive releaser.

USER MANUAL INDUSTRIAL DOOR LH/F

DOOR VIEW – VERTICAL CROSS-SECTION

Min 250 mm

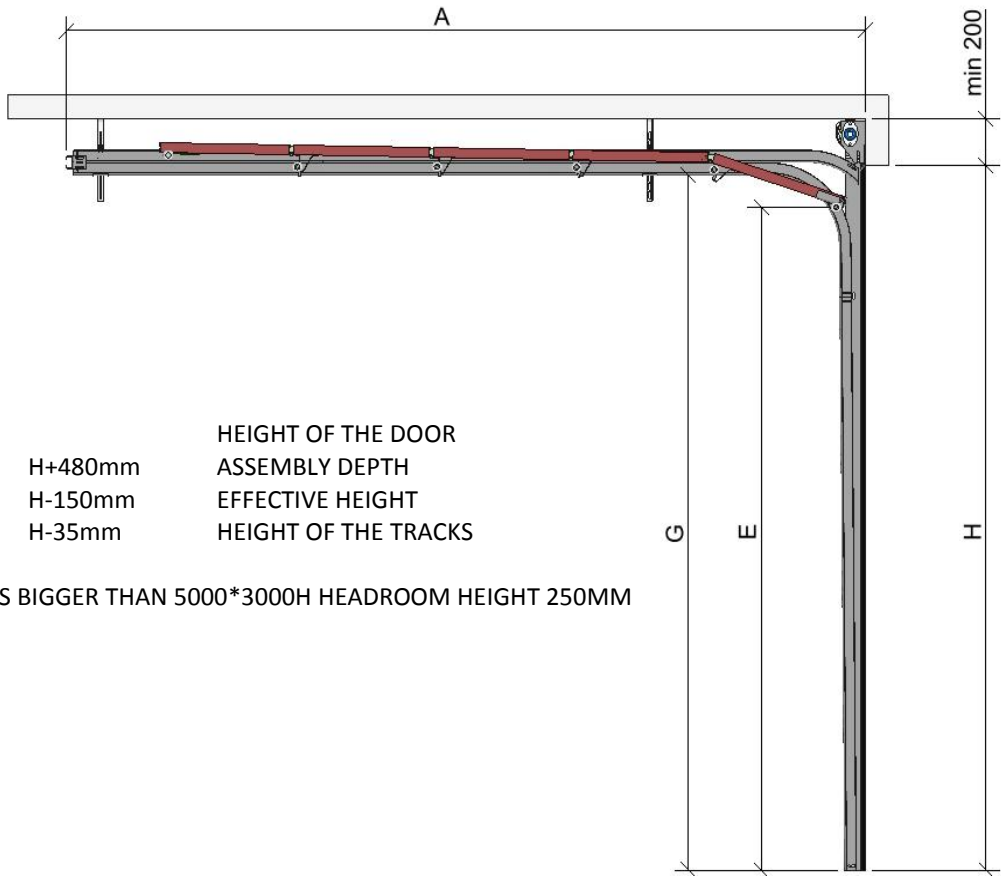

- H HEIGHT OF THE DOOR
- A H+480mm ASSEMBLY DEPTH
- E H-150mm EFFECTIVE HEIGHT
- G H-35mm HEIGHT OF THE TRACKS

DOORS BIGGER THAN 5000*3000H HEADROOM HEIGHT 250MM

DOOR VIEW – HORIZONTAL CROSS-SECTION



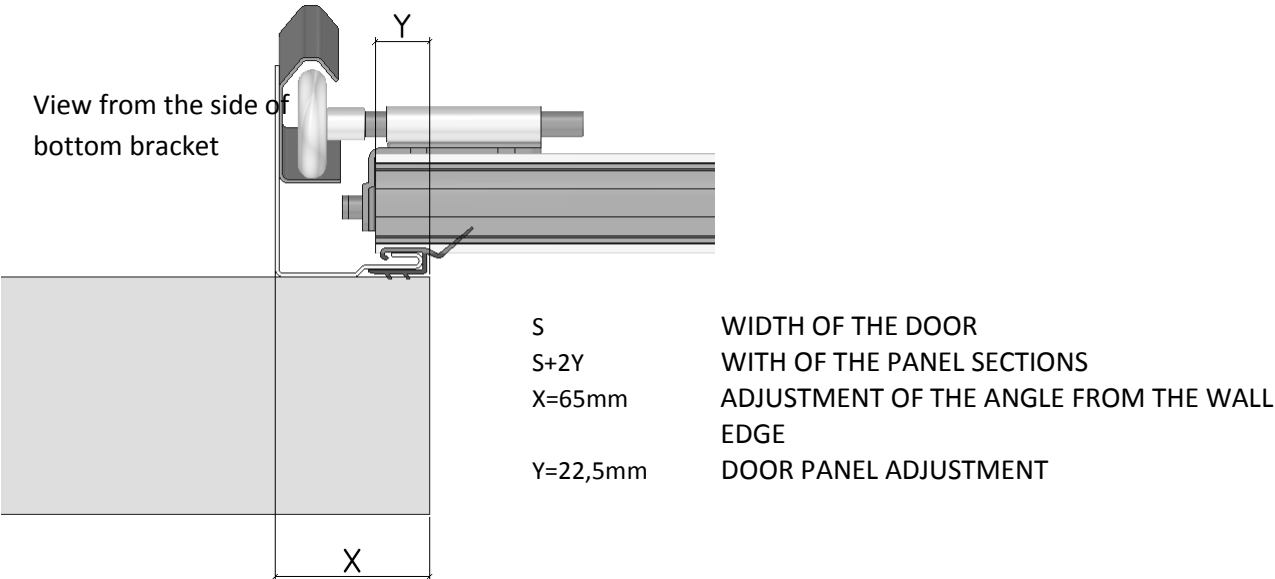

ASSEMBLY OF VERTICAL TRACKS SET

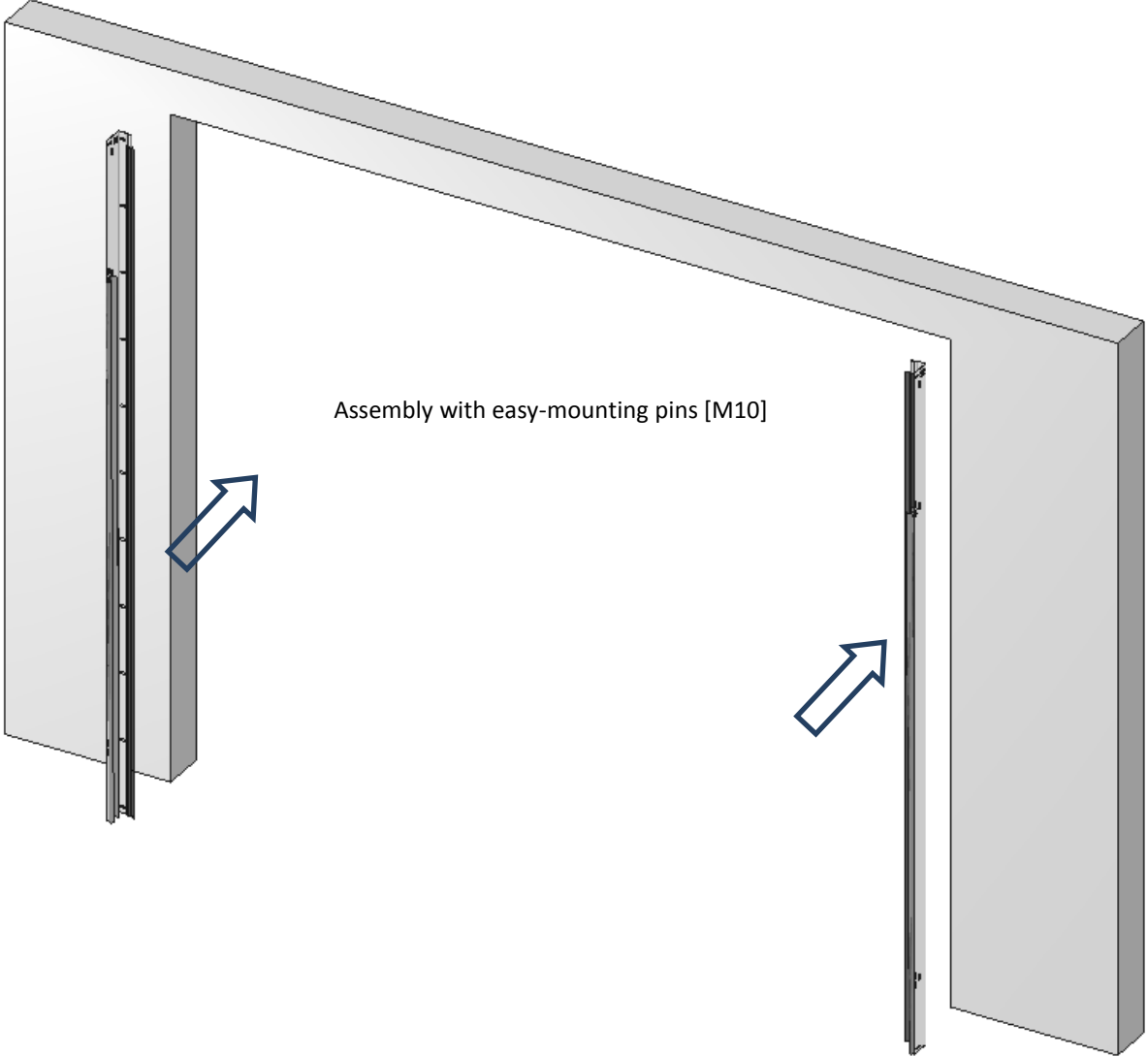

VIEW OF VERTICAL TRACK SET

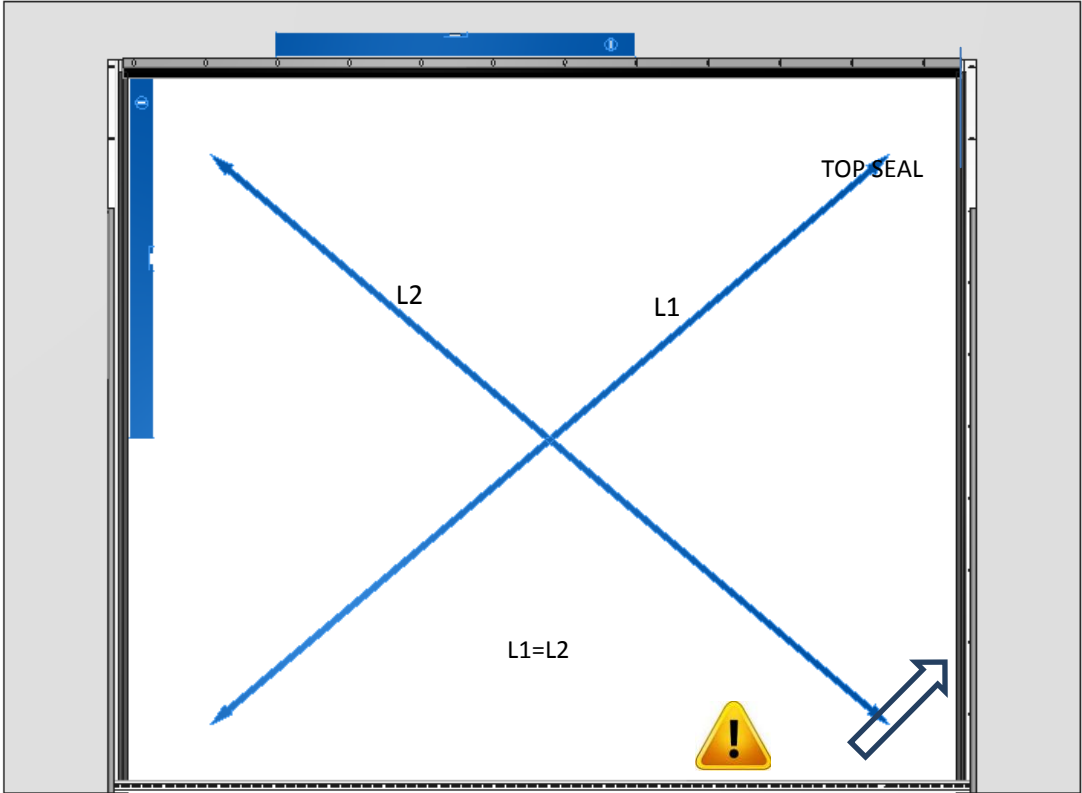
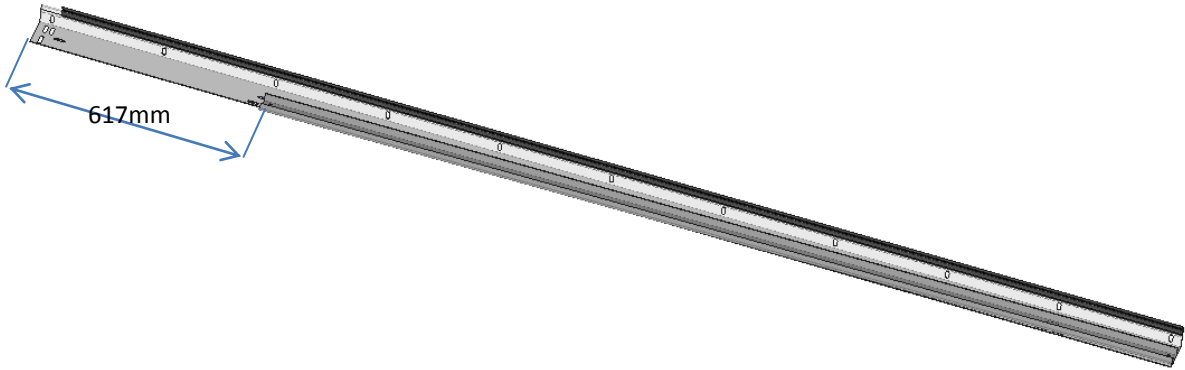

BEFORE TIGHTENING CHECK ALL VERTICAL AND HORIZONTAL ADJUSTMENTS AND LENGTHS OF DIAGONALS $L1=L2$

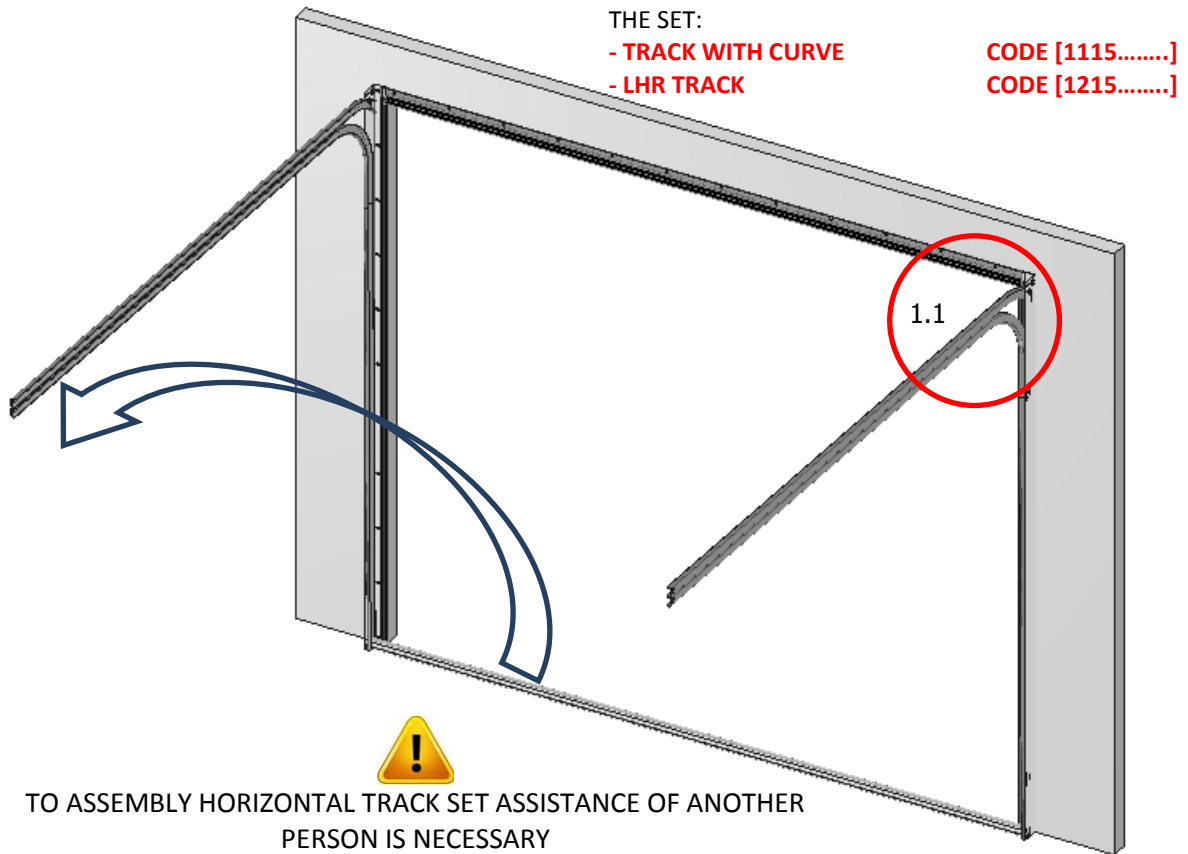

TO ASSEMBLY HORIZONTAL TRACK SET ASSISTANCE OF ANOTHER PERSON IS NECESSARY
ATTENTION

MOVE THE C-PROFILE TO THE END OF HORIZONTAL TRACK SET

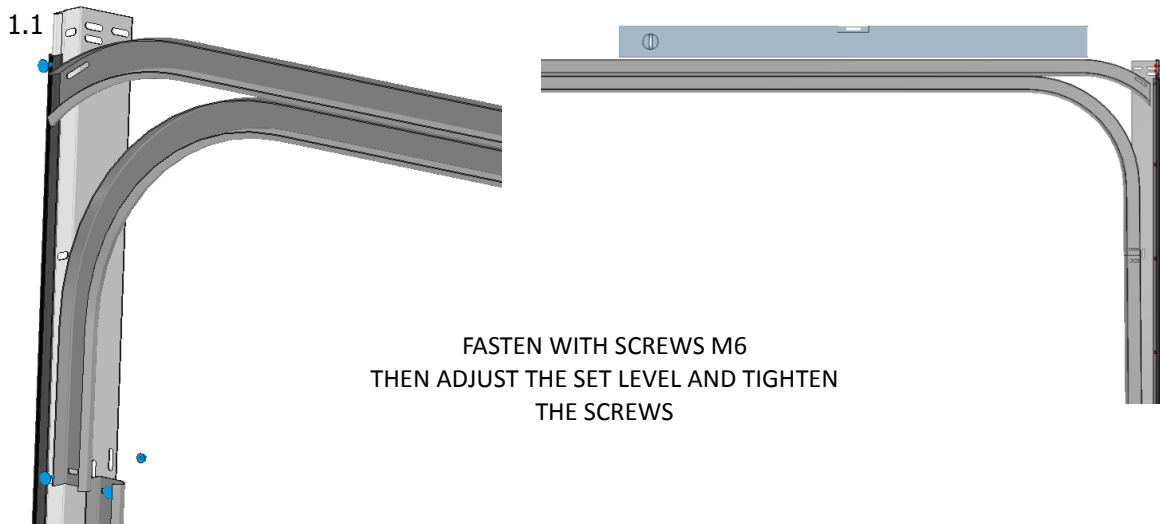

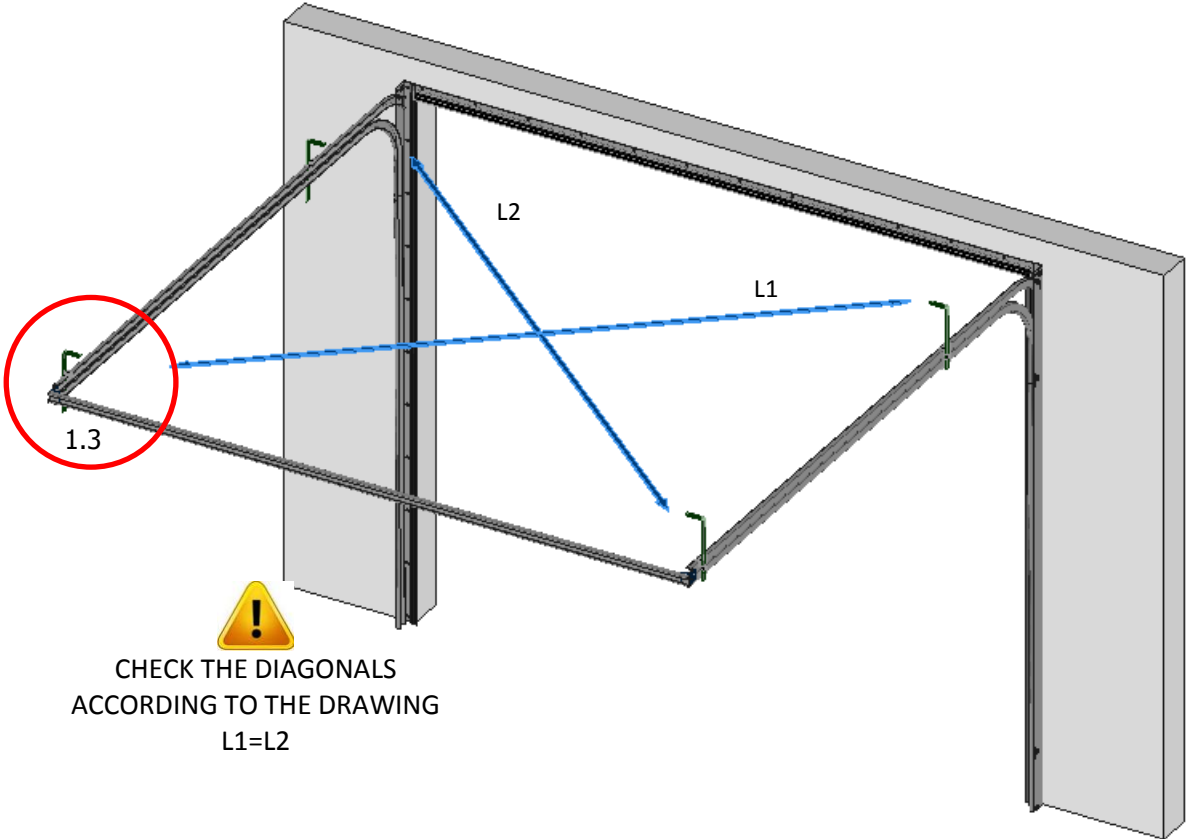

CHECK THE DIAGONALS
ACCORDING TO THE DRAWING
L1=L2

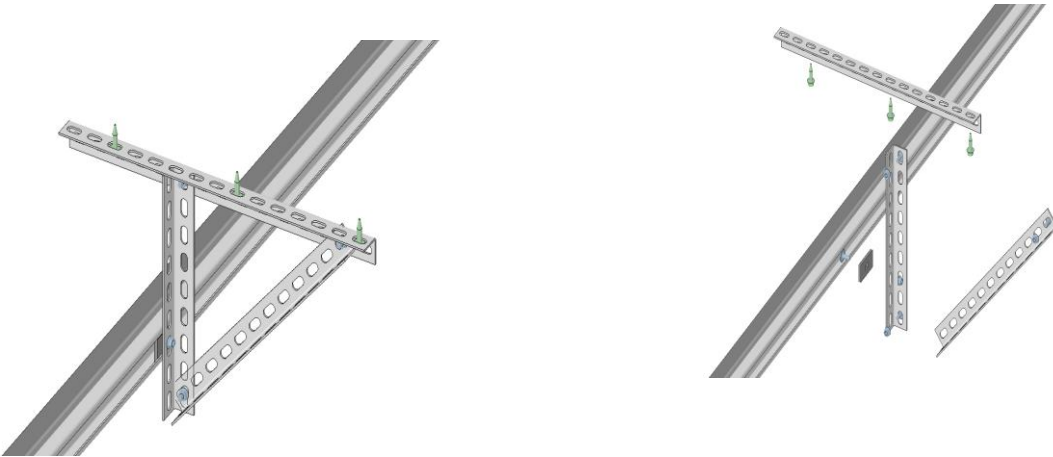

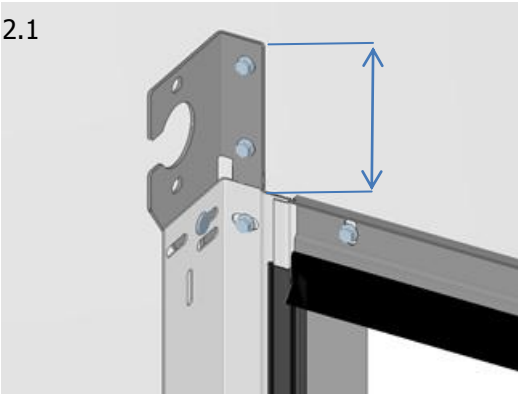
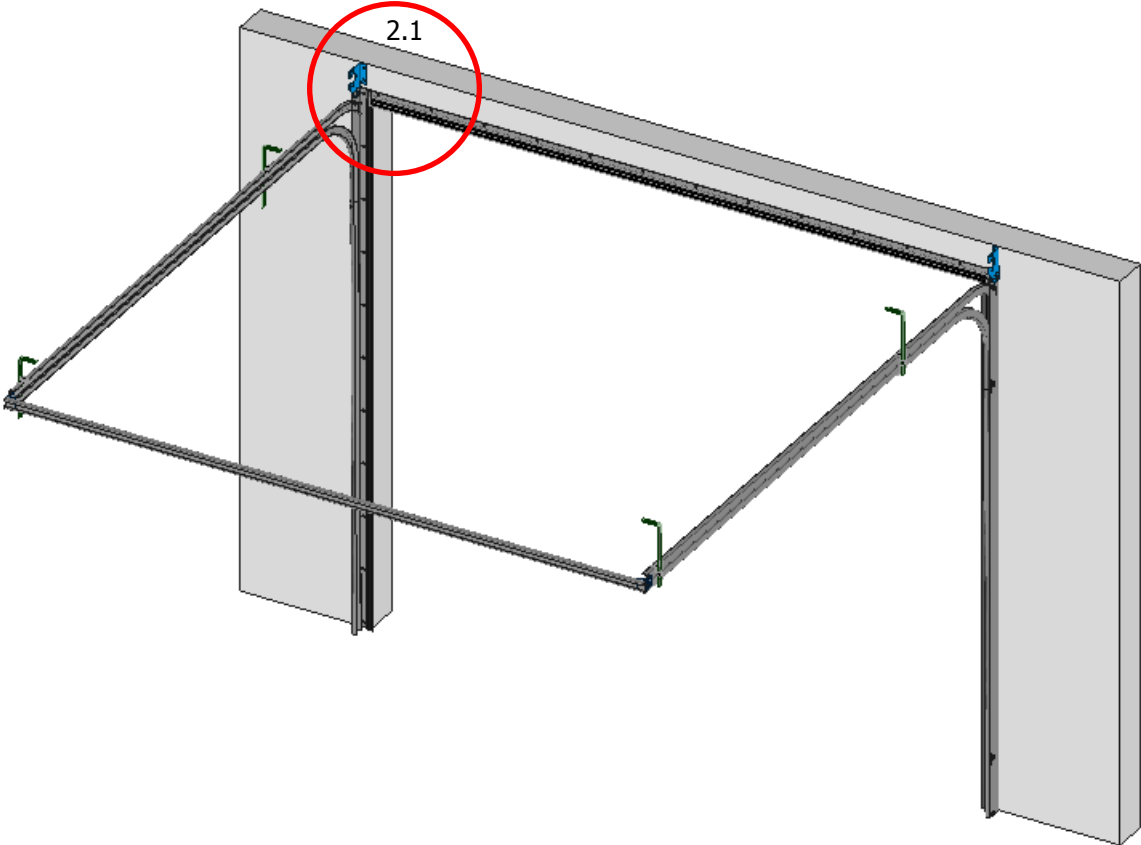

THE SET:
- SIDE SHAFT BRACKET CODE [503167]

Side shaft bracket to be settled directly on the vertical angle

ASSEMBLY OF THE SHAFT – INTERIOR SIDE VIEW



APPLY SPRING BREAK DEVICE!



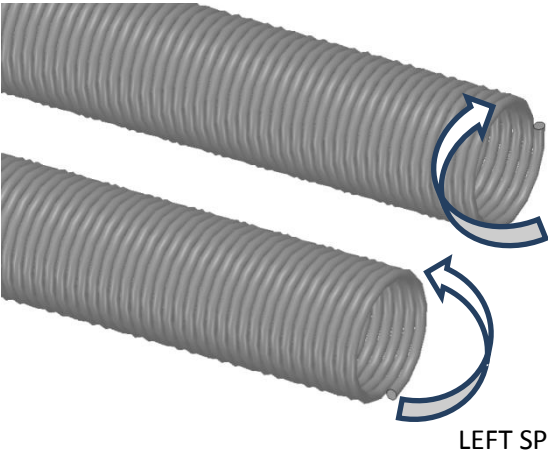

SPRINGS TO BE SELECTED FROM THE APPLICATION

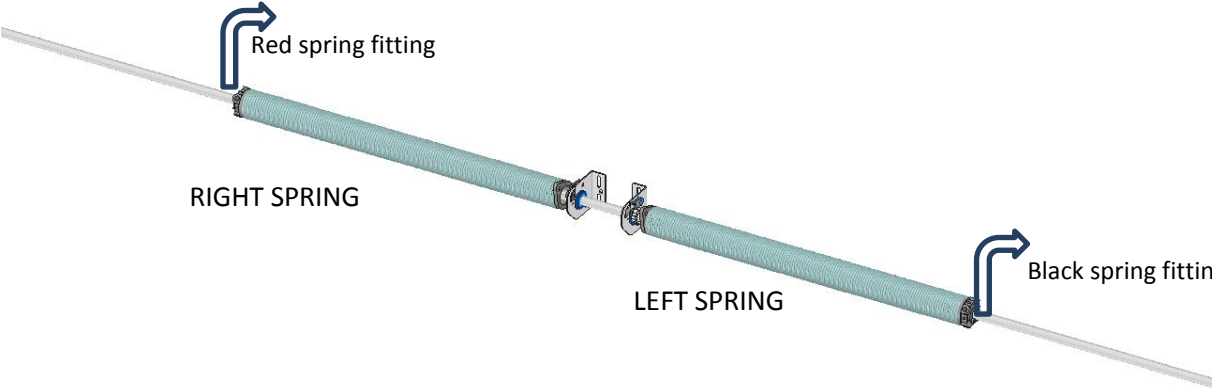

SHAFT ASSEMBLY

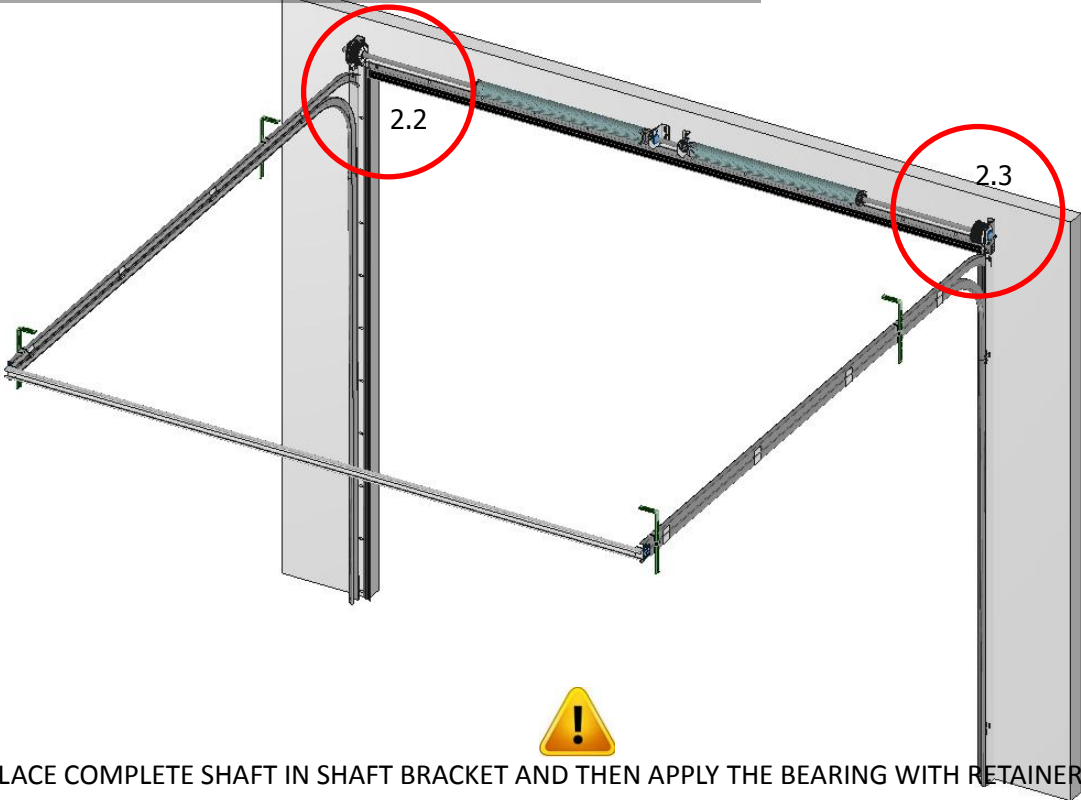

PLACE COMPLETE SHAFT IN SHAFT BRACKET AND THEN APPLY THE BEARING WITH RETAINER AT THE ENDS OF THE SHAFT AND SCREW WITH THE M8 BOLTS

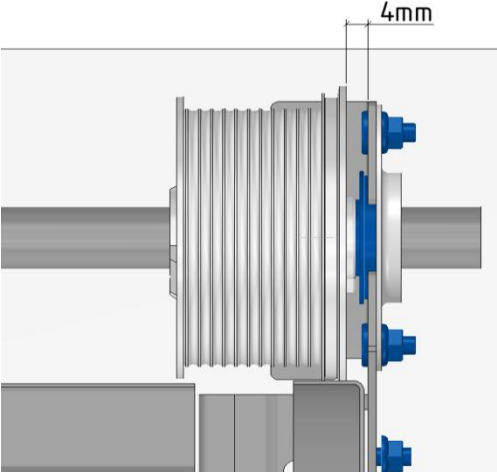
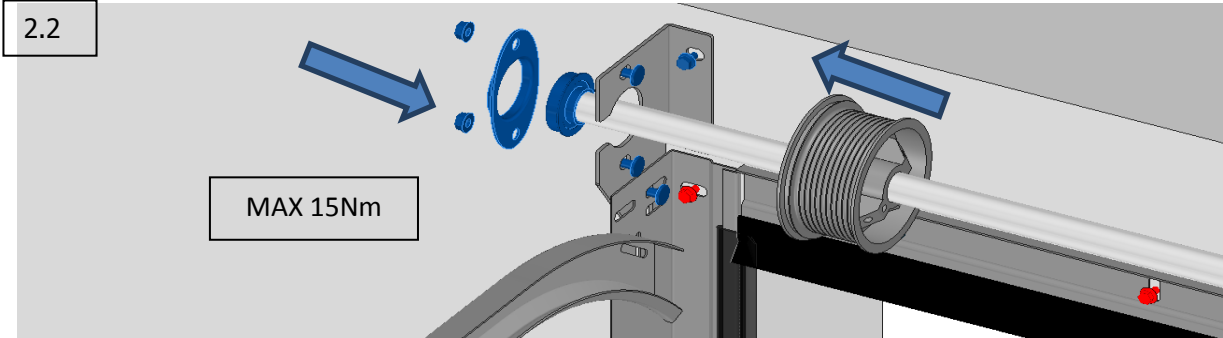

KEEP A DISTANCE

2.3

MONTGE OF FIRST PANEL SECTION

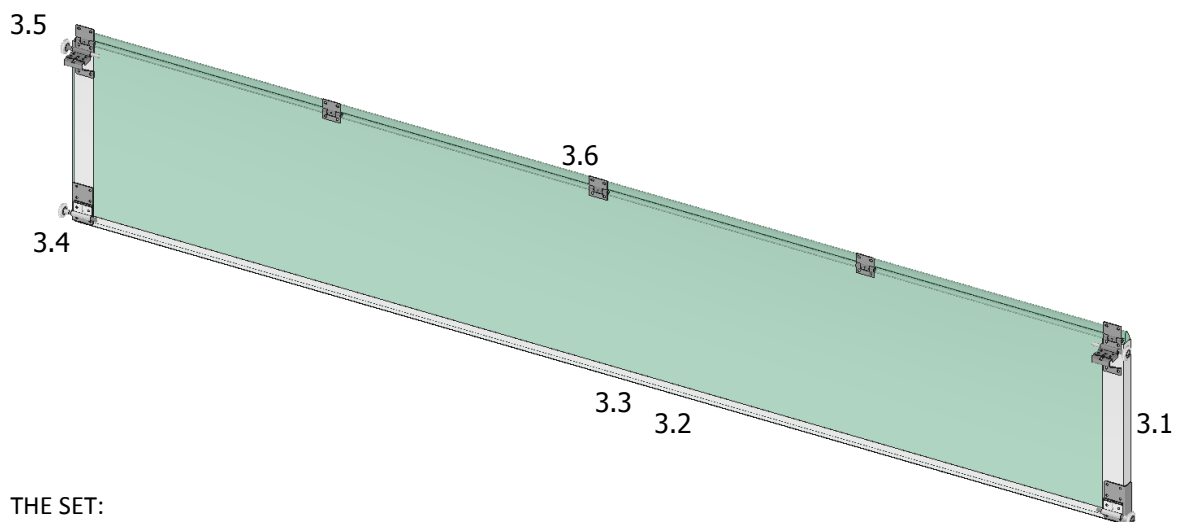
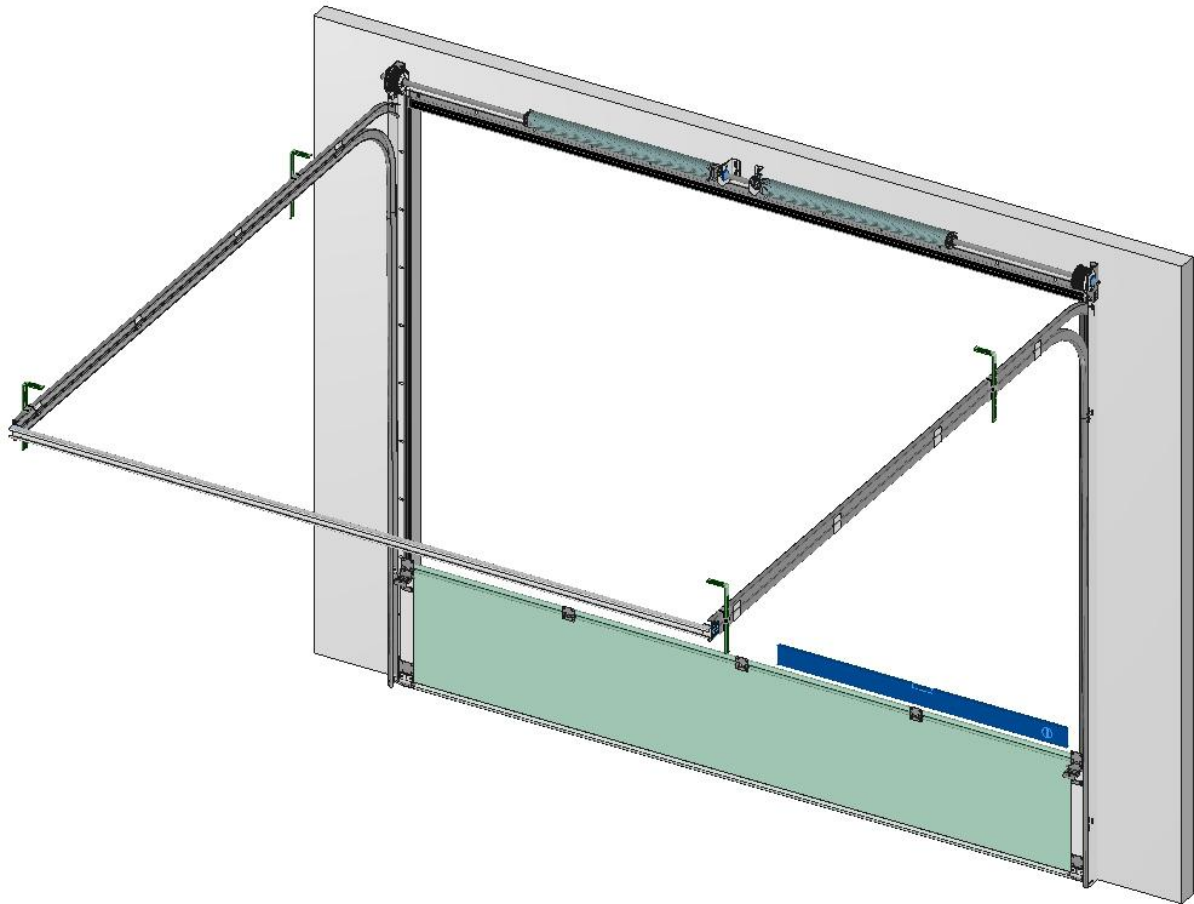

THE SET:

- 3.1 UNIVERSAL ENDCAP
- 3.2 BOTTOM ALUMINIUM PROFILE
- 3.3 BOTTOM SEAL
- 3.4 BOTTOM BTACKET
- 3.5 SIDE HINGE
- 3.6 MIDDLE HINGE

- CODE [4505....]
- CODE [2002....]
- CODE [3102....]
- CODE [4403....]
- CODE [4220....] ADJUST TO PANEL TYPE
- CODE [4220....M] ADJUST TO PANEL TYPE

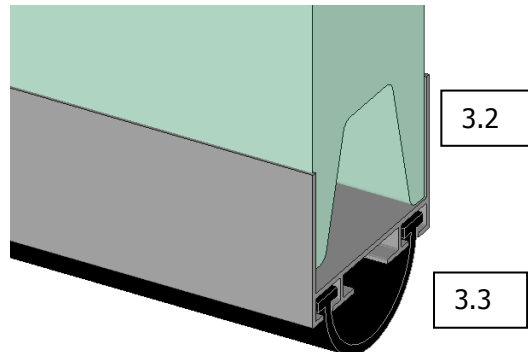
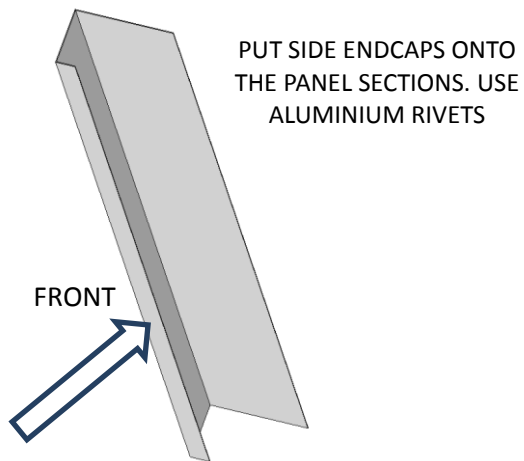

PUT ALUMINIUM PROFILE AND BOTTOM SEAL ONTO THE BOTTOM SECTION

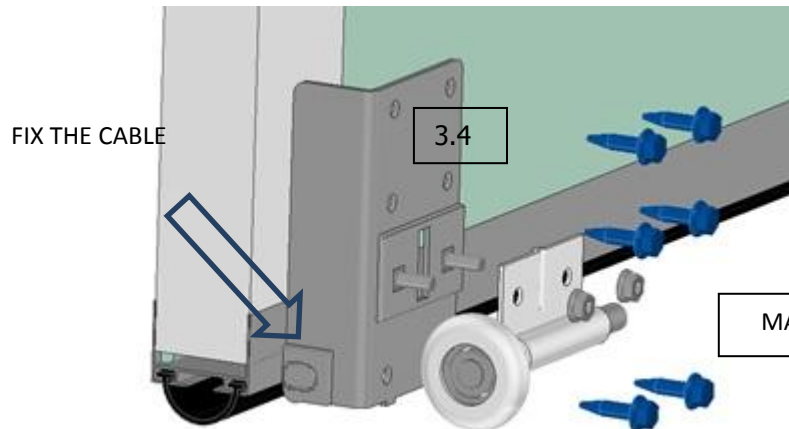

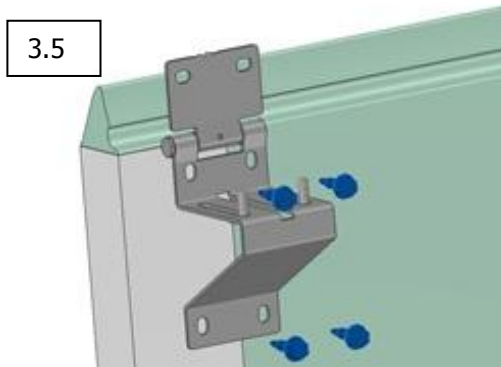

MONTAGE OF BOTTOM BRACKET. REGULATE THE ROLLER INSIDE THE TRACK

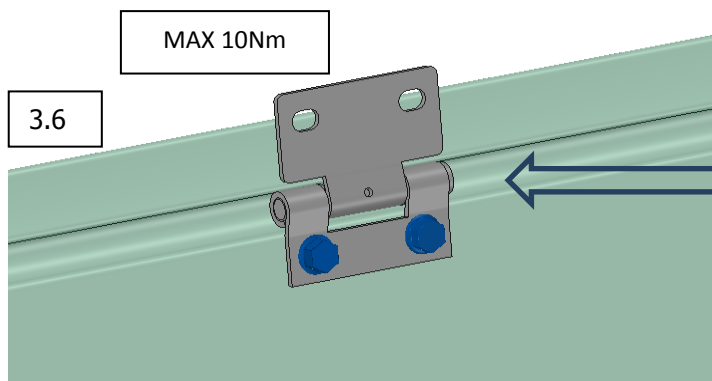

APPLY HINGES IN ACCORDANCE WITH PANEL PRODUCER DIRECTIONS

MAX 10Nm





APPLY THE HINGE IN ACCORDANCE WITH PANEL PRODUCER DIRECTIONS

For proper selection of number of middle hinges, use the following table:

Door width	Number of middle hinges
0-2749	1
2749-3999	2
3999-5000	3

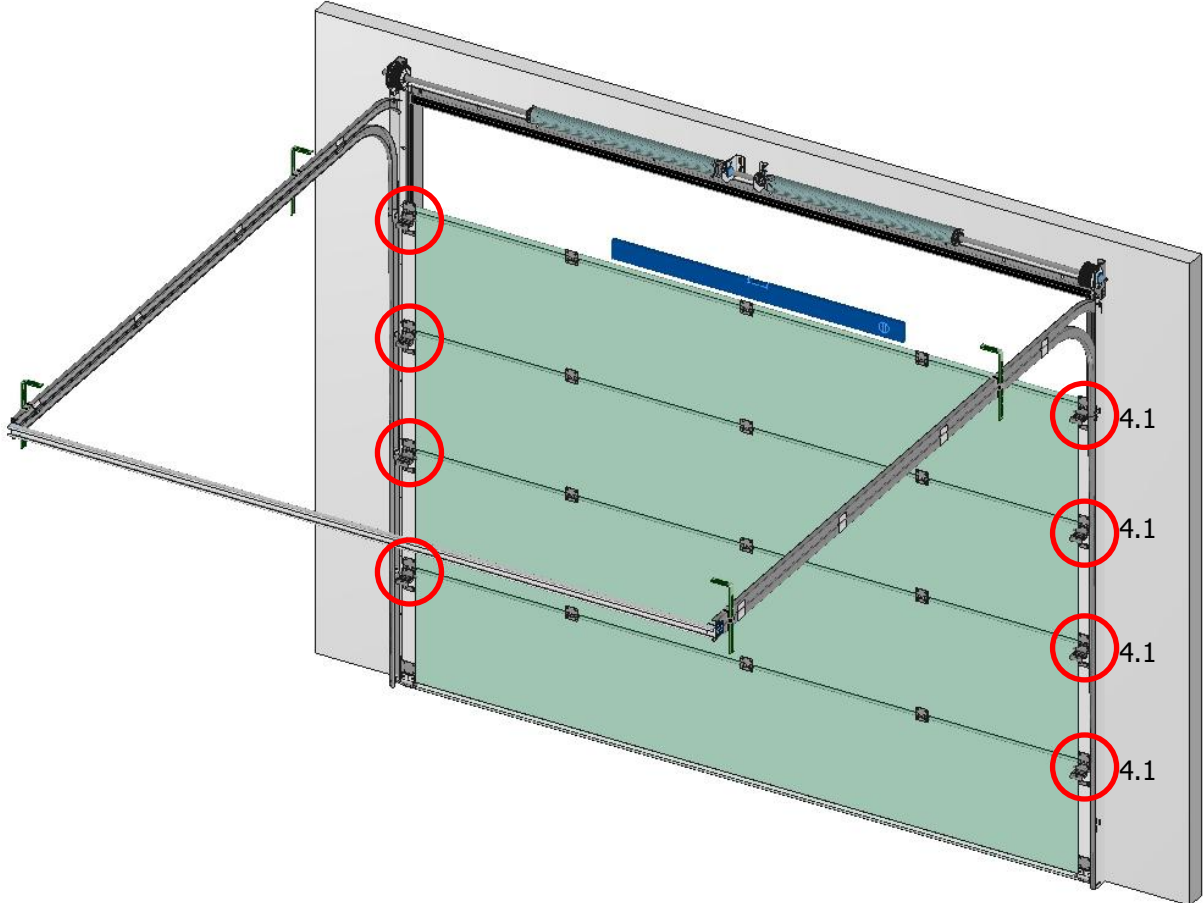
MONTAGE OF THE OTHER PANEL SECTIONS



4.1

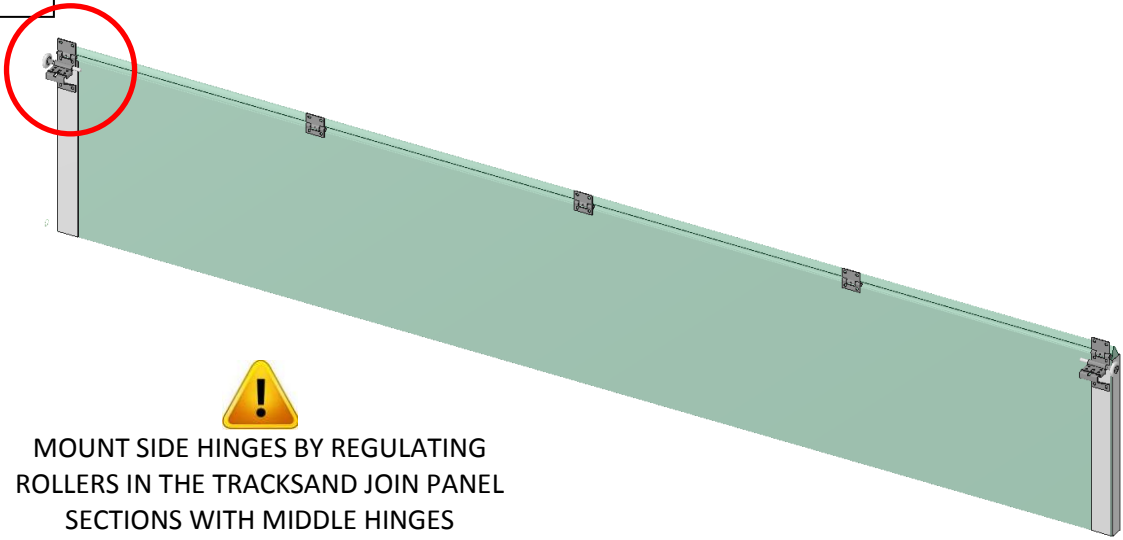

4.1

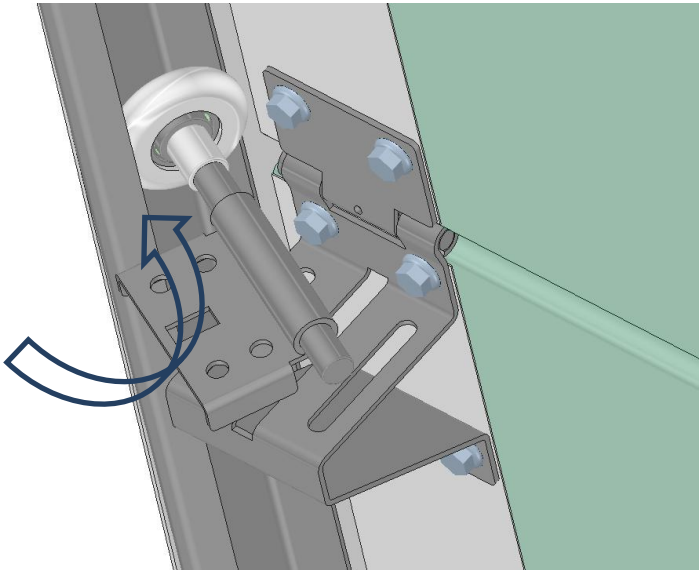

ATTENTION
PUT A ROLLER INSIDE A TRACK FIRST
AND THEN FIX IT TO THE HINGE

MONTAGE OF THE TOP PANEL SECTION

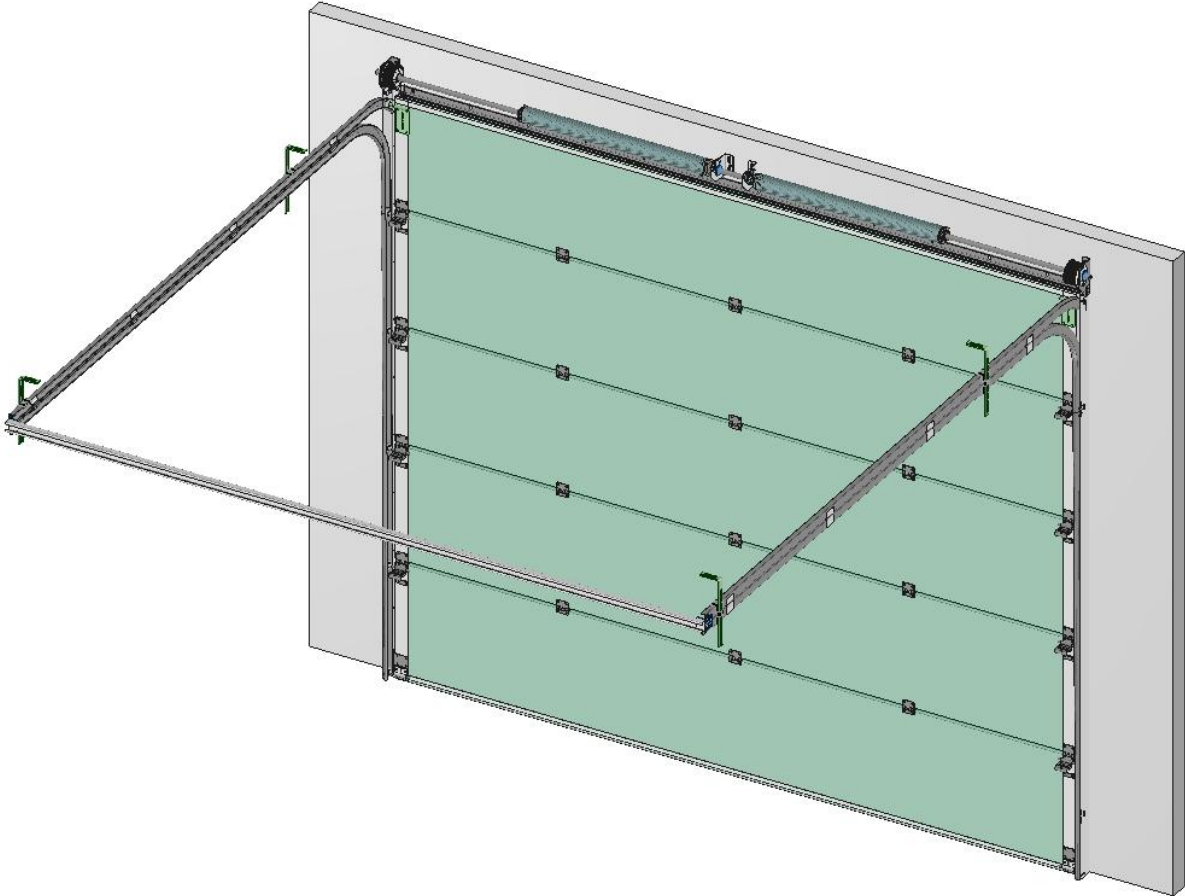

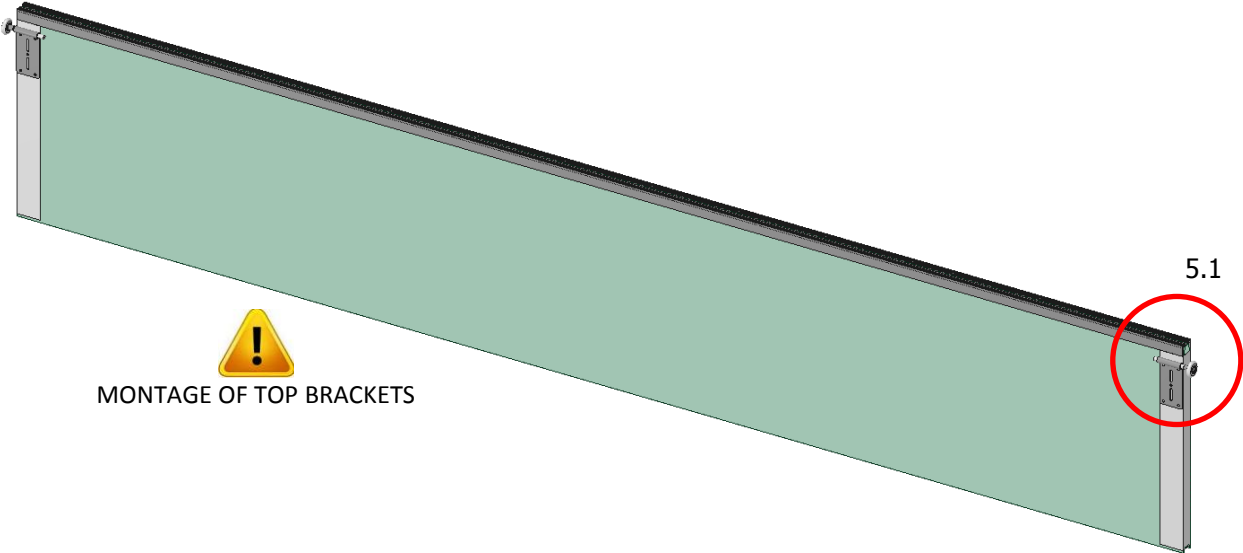

MONTAGE OF TOP BRACKETS

5.1

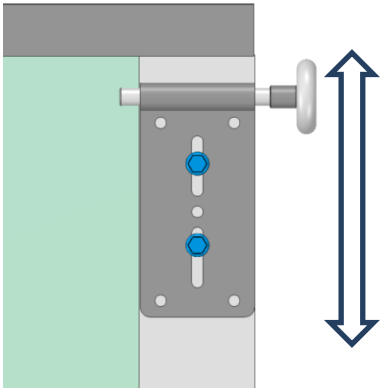
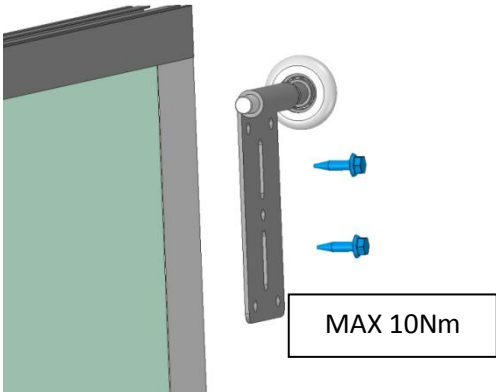

ADJUST THE TOP BRACKET WITH INSIDE SCREWS

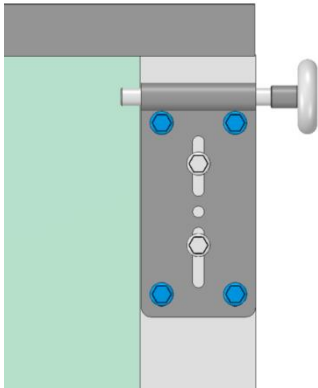

AFTER ADJUSTMENT TIGHTEN THE BRACKET WITH THE BOLTS

**OPTION:
APPLICATION OF THE SEAL TO ALUMINIUM PROFILE ABOVE TOP PANEL**

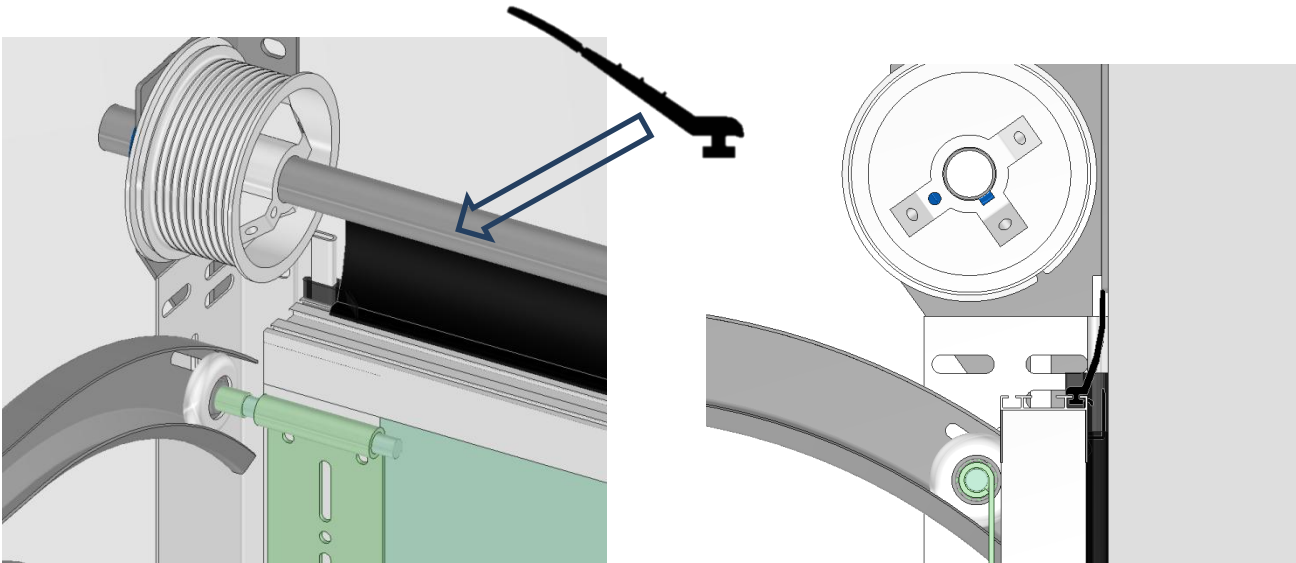

MONTAGE OF STEEL CABLE

PUT THE CABLE THROUGH THE CABLEDRUM AND TIGHTEN IT

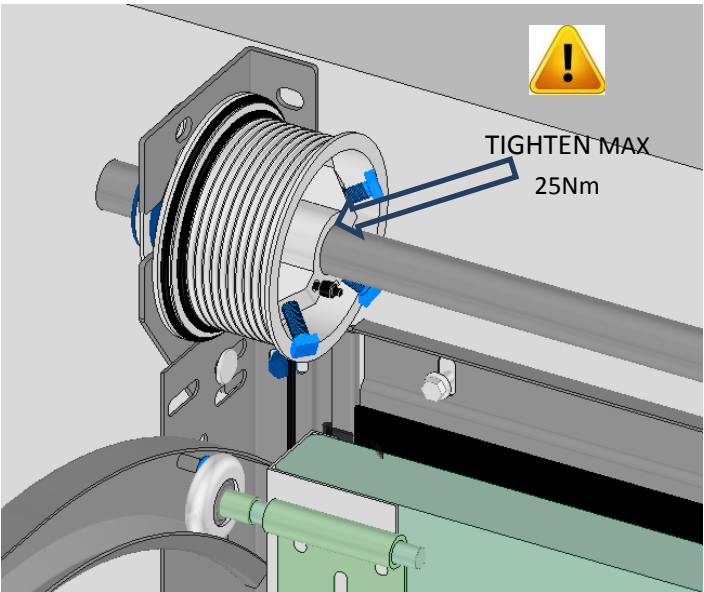
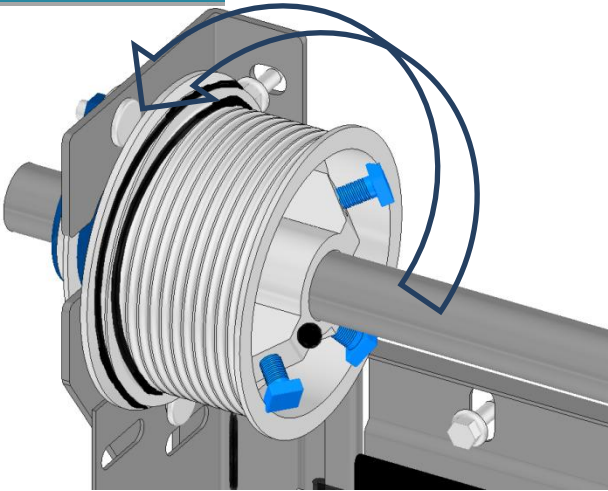

SPRING WINDING UP – INTERNAL SIDE VIEW

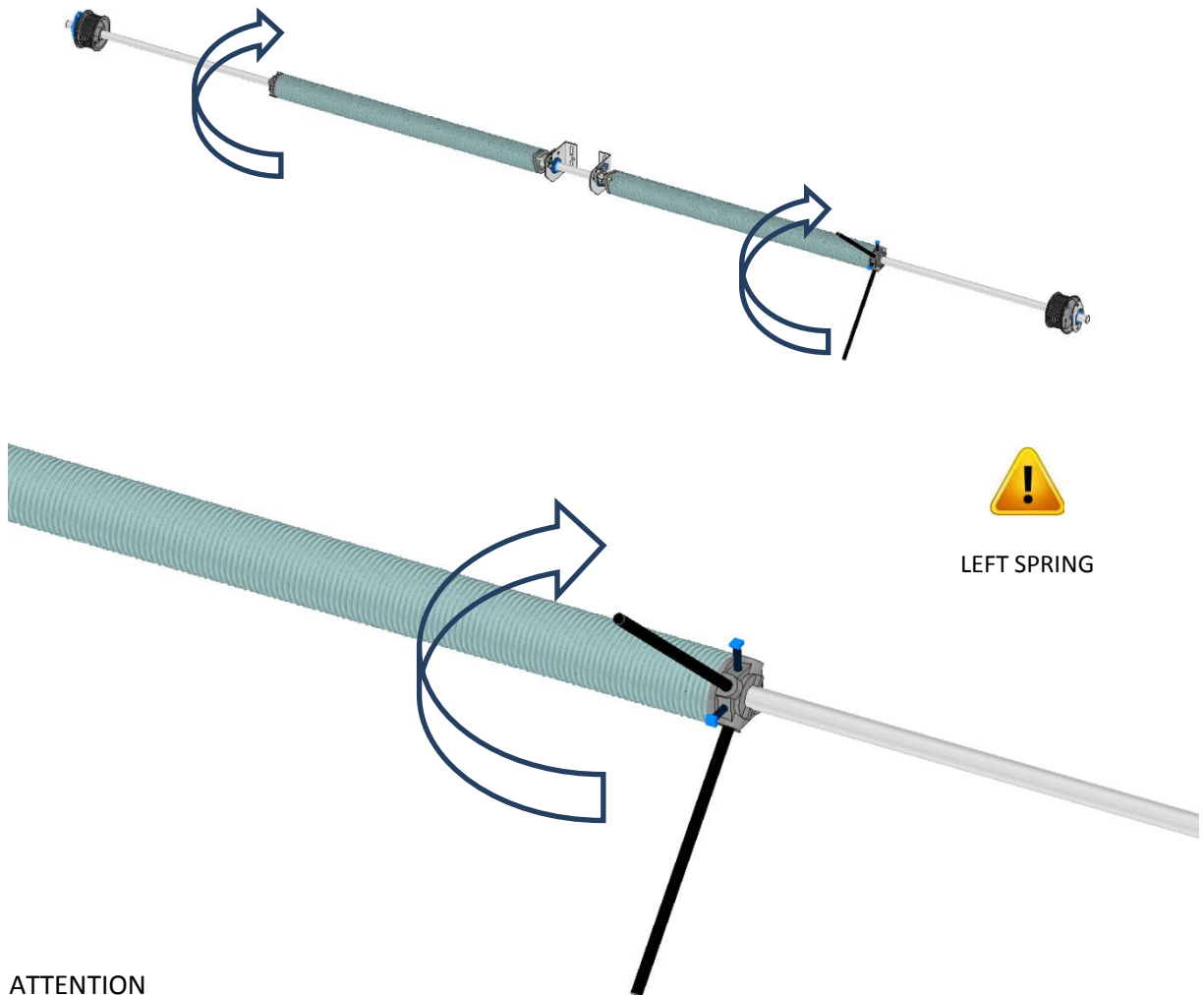

LEFT SPRING

ATTENTION
DURING TURNING OF TORSIONS SPRING IT IS NECESSARY TO USE HIGH STRENGTH. BE CAREFUL.
MONTAGE, SERVICE, MAINTANANCE AND REPAIRS CAN ONLY BE PERFORMED BY QUALIFIED STAFF.

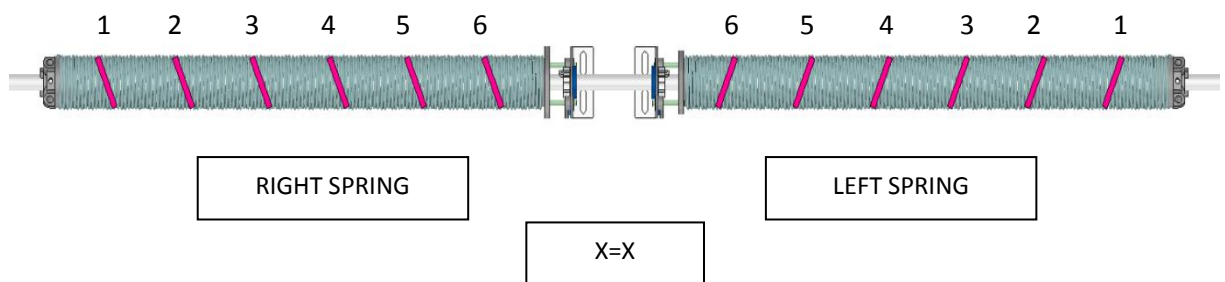

spring turns see lable on door panels

SPRINGS TO BE TURNED AS PER THE TABLE WITH
SPRING TURNS



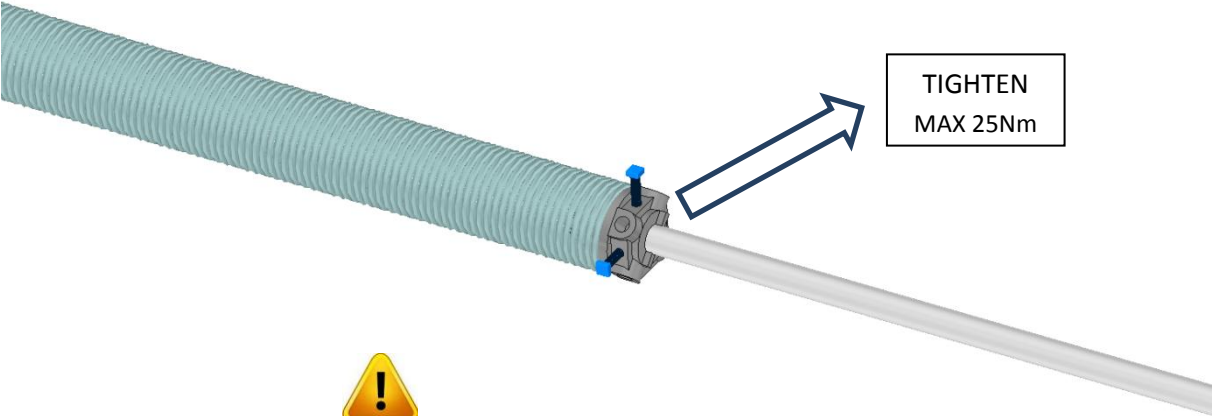

FOR GARAGE DOORS OF HEIGHT $\geq 3000\text{mm}$ USE A SHAFT WITH KEYWAY AND A SHAFT COUPLER

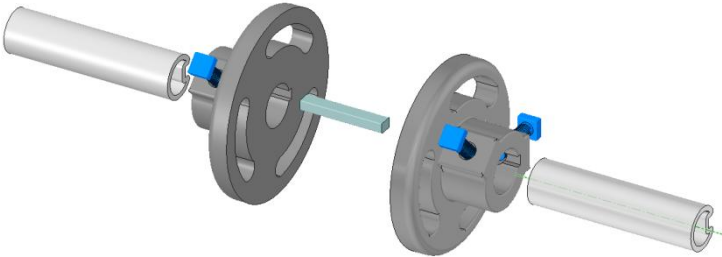

ATTENTION

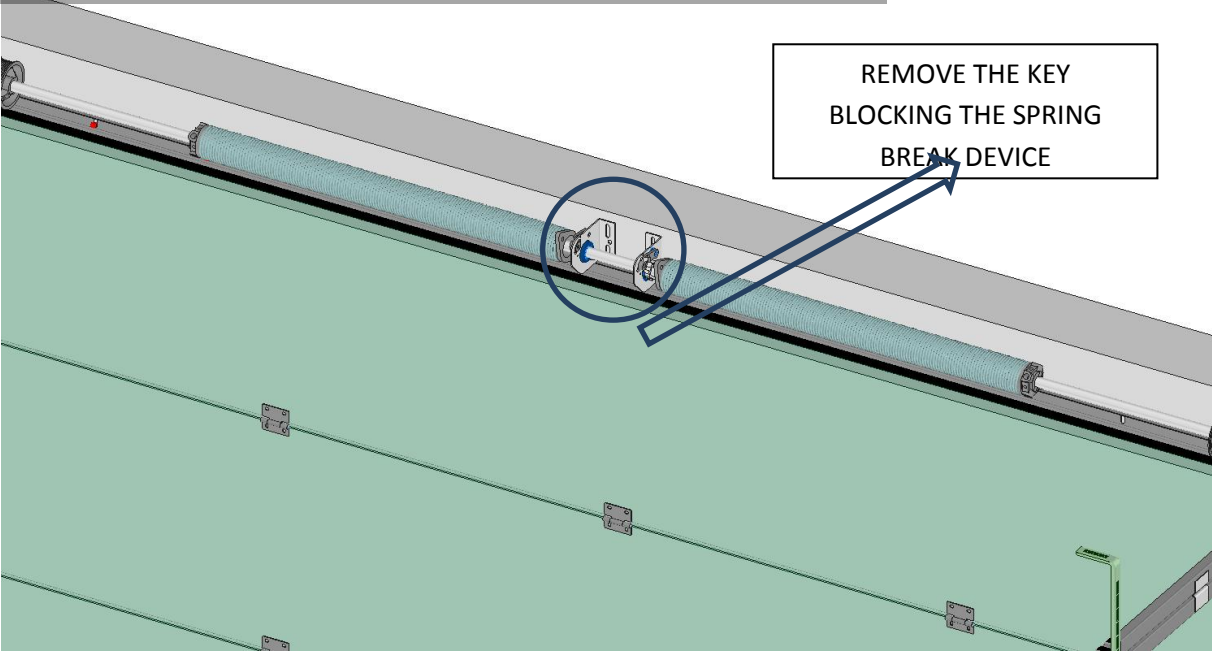

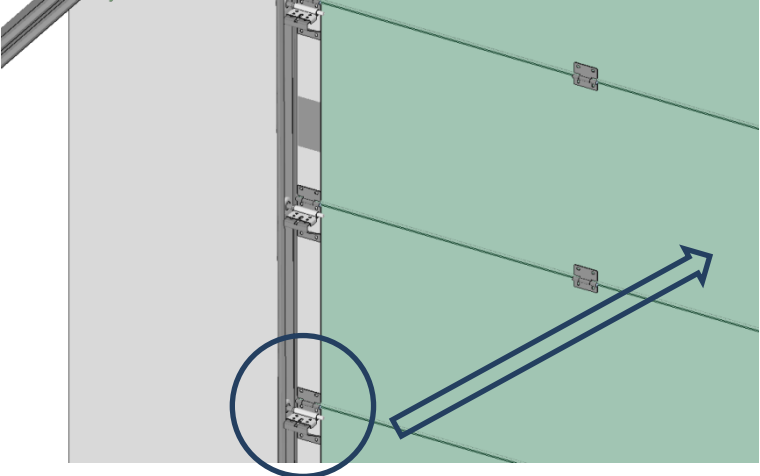

The name or the identification sign and registered address of the producer

The last two digits of the year, when the marking was placed

EN 13241-1
The number of European norm

Description of the product and intended use
Identification number

Water resistance [technical class]

Wind load resistance [technical class]

Thermal resistance [value]

Air permeability [technical class]
Information about the required quality of the product

CE

Conformity CE marking by using CE mark
Determined in the directive 93/68/EEC

89/106/EEC; 98/37/EC; 89/336/EEC
Issuing appropriate directives

